

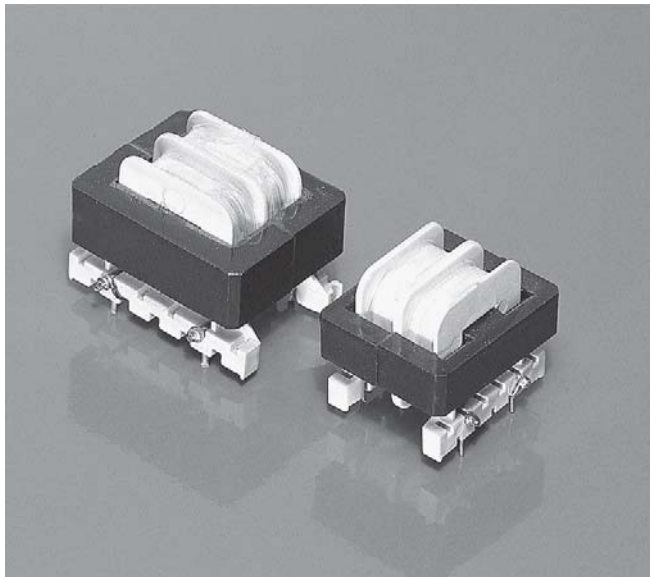

# Common Mode Line Chokes – EE Styles



- Low cost
- VDE, IEC, UL, CSA compliant
- 3750 Vrms isolation between windings
- Constructed with UL approved Class 130°C insulation system (UL File E83628)
- Industry-standard EE25 size
- Wide range of available inductances and current ratings

Coilcraft **Designer's Kit No. P402** contains samples of eight standard EE and toroidal common mode line chokes. To order, contact Coilcraft or purchase on-line at <http://order.coilcraft.com>.

Coilcraft common mode standard packages incorporate several features to help meet the requirements of all major international safety agencies. These include 2 mm thick center flanges and 3 mm creepage and clearance from all terminations to the core.

Common mode chokes are used to reduce AC line conducted interference produced by switching power supplies. This configuration produces opposing magnetic fluxes in the core that serve to cancel in-phase noise signals appearing across the AC line.

This mode allows much more filtering capability in a given core size than would be possible using differen-

tial filtering alone. Use of common mode chokes therefore reduces component count as well as inductor size.

Combining both common and differential mode chokes gives the power supply designer the added flexibility required to adjust the filtering to meet FCC, VDE, and other requirements as well as optimize the circuit for the particular noise levels and frequencies produced by each power supply design.

The Coilcraft packaging of common mode chokes allows windings to be balanced within 1% and features the cost effectiveness of standard EE core styles.

## Schematic

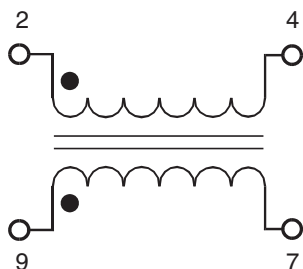

## Typical Application

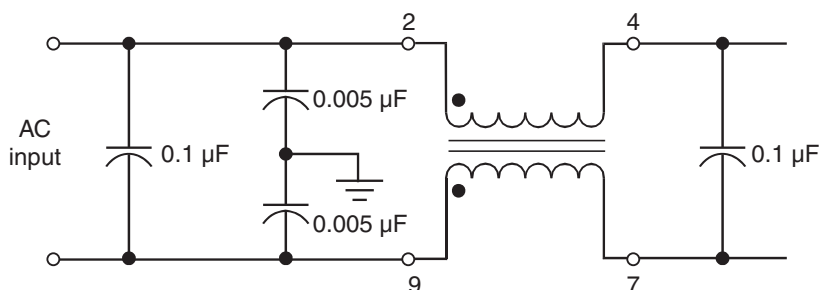

**Coilcraft**<sup>®</sup>

Specifications subject to change without notice.  
Please check our website for latest information.

Document 141-1 Revised 02/06/06

1102 Silver Lake Road Cary, Illinois 60013 Phone 847/639-6400 Fax 847/639-1469

E-mail [info@coilcraft.com](mailto:info@coilcraft.com) Web <http://www.coilcraft.com>



# Common Mode Line Chokes – EE Styles

## Standard EE Line Chokes

Part number	Current rating <sup>1</sup>	DCR max <sup>2</sup> (Ohms)	Inductance <sup>3</sup> min
<b>E3490-AL</b>	500 mA	0.980	9.9 mH
E3491-AL	750 mA	0.390	3.9
E3492-AL	1 A	0.270	2.9
<b>E3493-AL</b>	1¼ A	0.190	2.1
E3494-AL	1½ A	0.105	1.1
<b>E3495-AL</b>	2 A	0.069	731 µH
E3496-AL	2½ A	0.044	468
E3497-AL	3 A	0.029	299
E3498-AL	4 A	0.016	168

- Based on 300 circular mils/Amp. Temperature rise is less than 10°C.
- DCR is maximum per winding.
- Per section. Typical values are approximately 30% higher than published minimums.
- Operating temperature range –40°C to +85°C.
- Electrical specifications at 25°C.
- Parts in bold type are included in Coilcraft Designer's Kit No. P402.

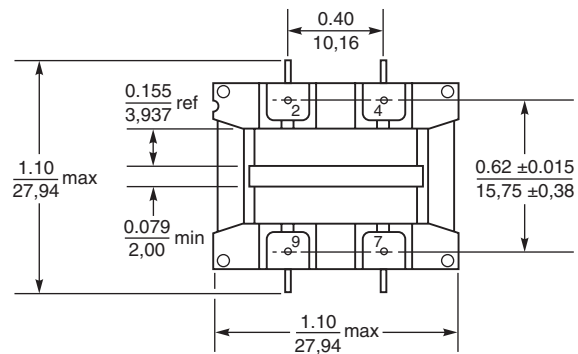
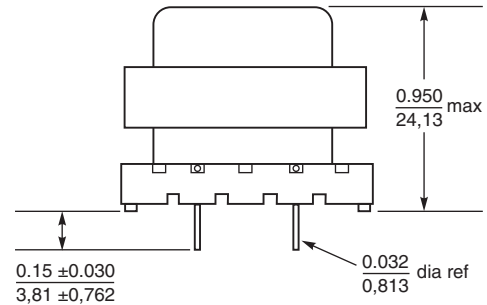

**Weight:** 19 – 33.8 g  
**Terminations:** Tin-silver over tin over copper

## Standard EE Line Chokes – High Inductance

Part number	Current rating <sup>1</sup>	DCR max <sup>2</sup> (Ohms)	Inductance <sup>3</sup> min
E3499-AL	500 mA	1.260	16.8 mH
E3500-AL	750 mA	0.500	6.6
E3501-AL	1 A	0.350	4.9
E3502-AL	1¼ A	0.230	3.6
E3503-AL	1½ A	0.130	1.87
E3504-AL	2 A	0.087	1.24
E3505-AL	2½ A	0.055	796 µH
E3506-AL	3 A	0.037	508
E3507-AL	4 A	0.022	286

- Based on 300 circular mils/Amp. Temperature rise is less than 10°C.
- DCR is maximum per winding.
- Per section. Typical values are approximately 30% higher than published minimums.
- Operating temperature range –40°C to +85°C.
- Electrical specifications at 25°C.

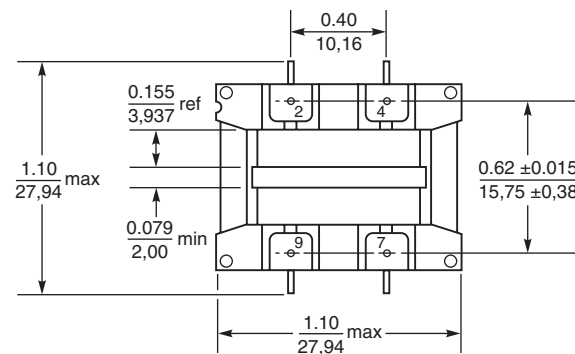
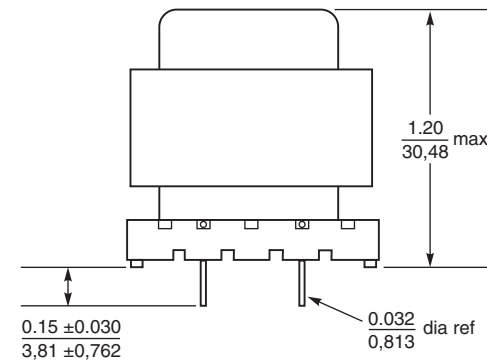

**Weight:** 19 – 33.8 g  
**Terminations:** Tin-silver over tin over copper

For custom values or information on toroidal common mode line chokes, please contact Coilcraft.

**Coilcraft**®

Specifications subject to change without notice.  
 Please check our website for latest information.

Document 141-2 Revised 02/14/06